

SPUTNIC



Hybrid transit buses

François BADIN - INRETS LTE
Lyon Bron France

2nd Working Group Meeting
4 – 5 October, Zagreb

Energy and local pollutant emission :

- Optimize i.c. engine working condition,
- Capture energy during braking,
- Optimize auxiliaries overall efficiency,

Additional features :

- New drivetrain architectures,
- ZEV range,
- Diversify primary energy consumption

Drivetrain possible architectures

« High floor »

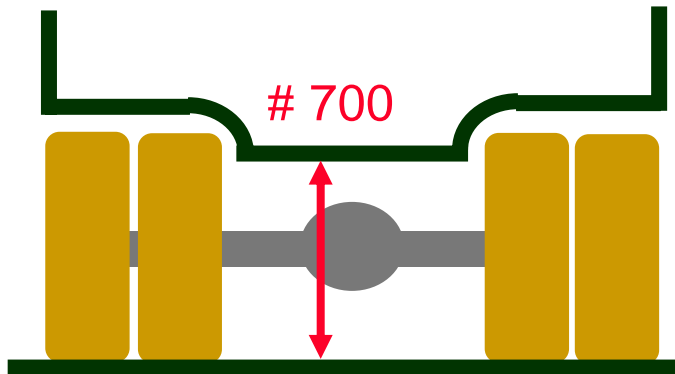

Low floor
non integral

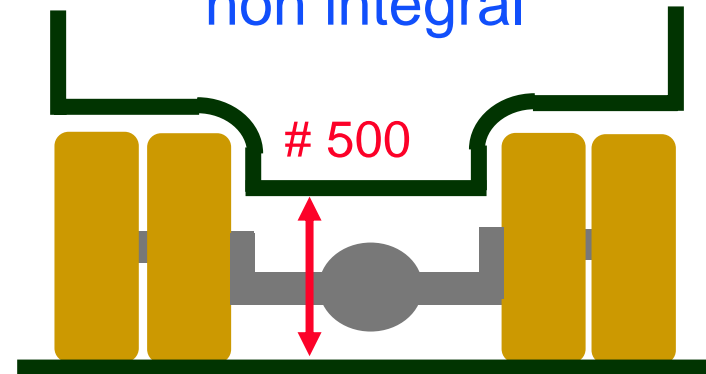

True low floor
« narrow »

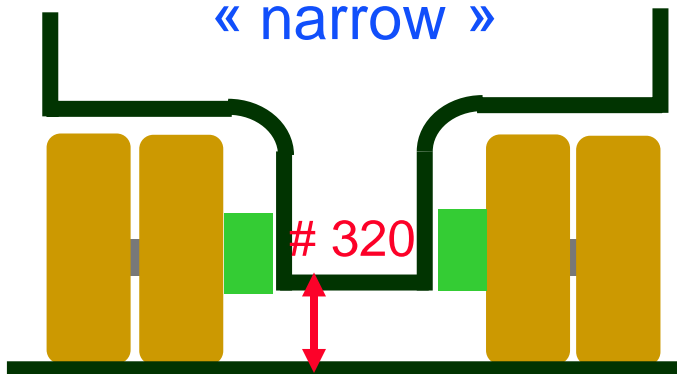

True low floor
« wide »

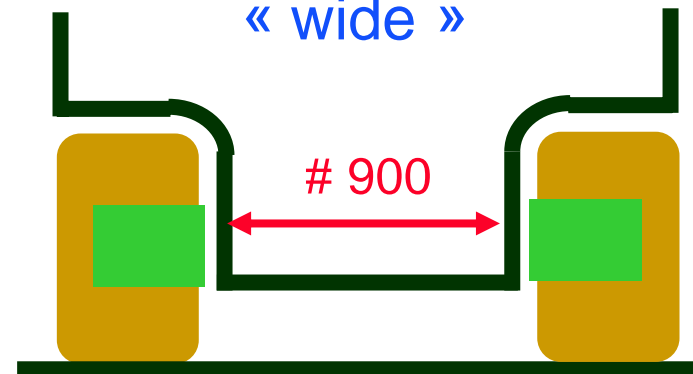

Collaboration Alstom, Irisbus, Michelin

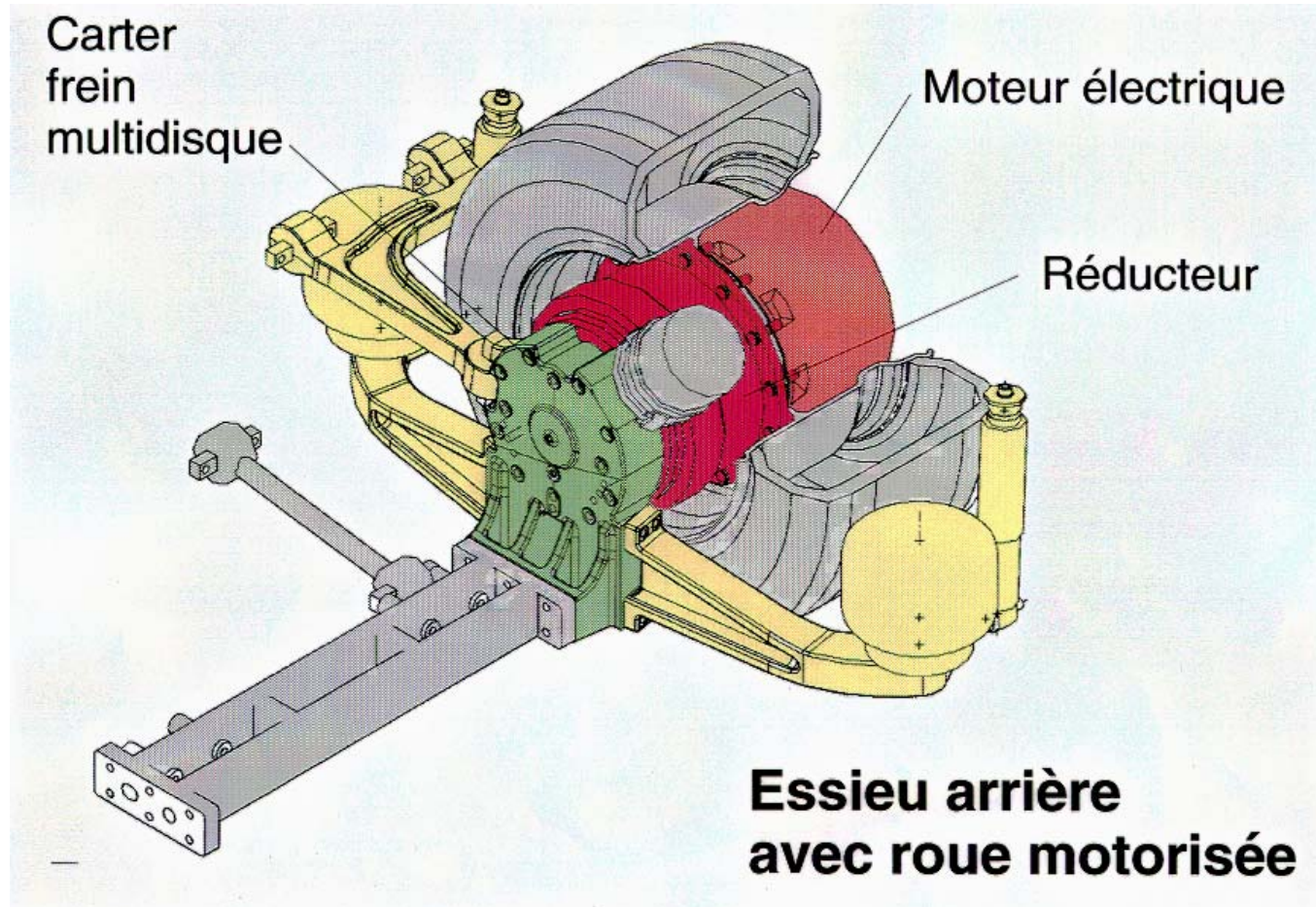



Diesel electric and series architectures :

- Engine disconnected from the wheels,
- Vehicle propelled by el. machine only,
- Low drivetrain efficiency,
- Deep architecture modification.

Diesel-electric solution

Irisbus, Alstom

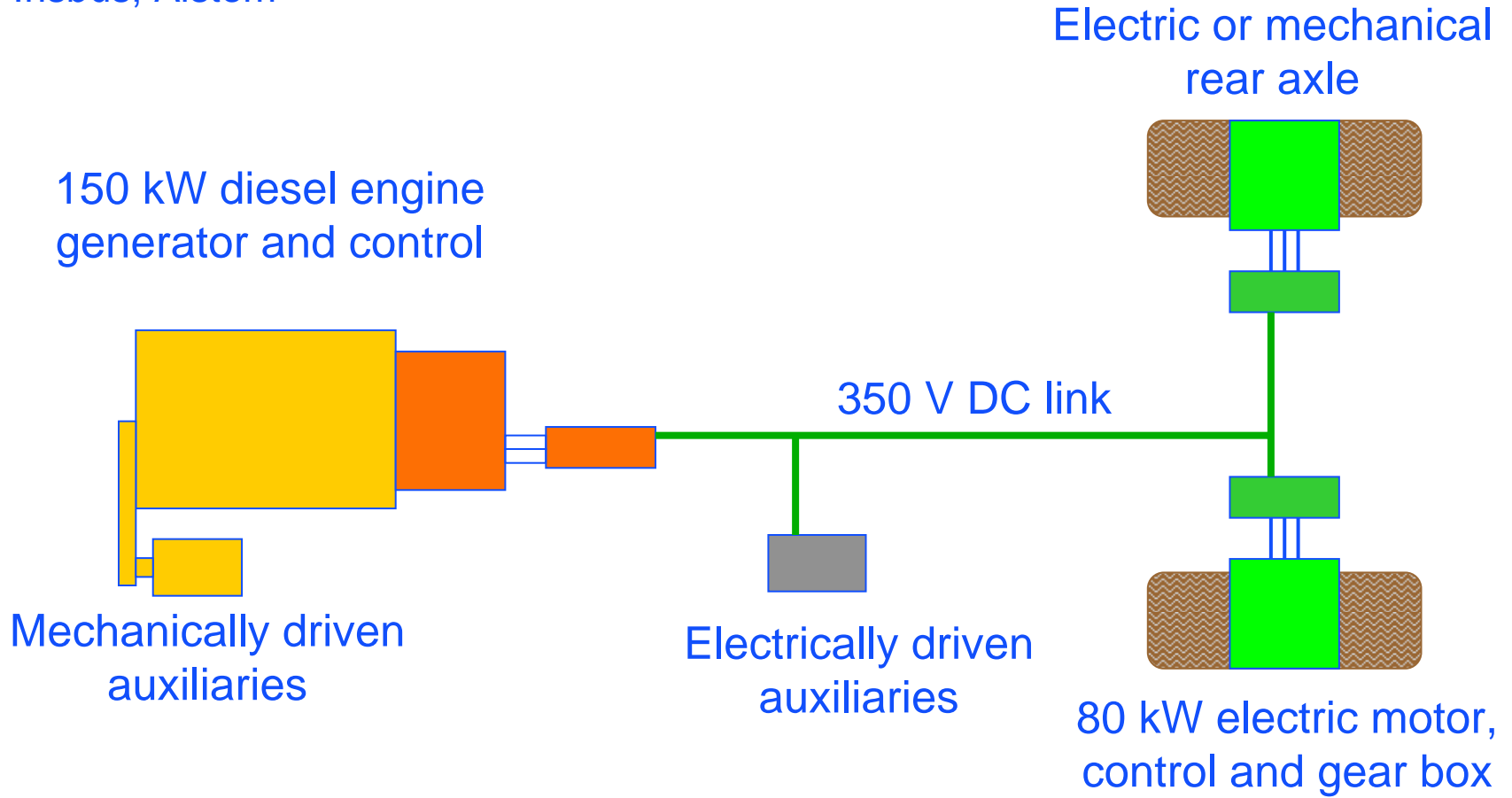

Consumption # conventional bus (or higher)

Irisbus, Alstom, Michelin

Prototype



Diesel-electric
Mercedes CITO (2202)



Civis



Cristalis

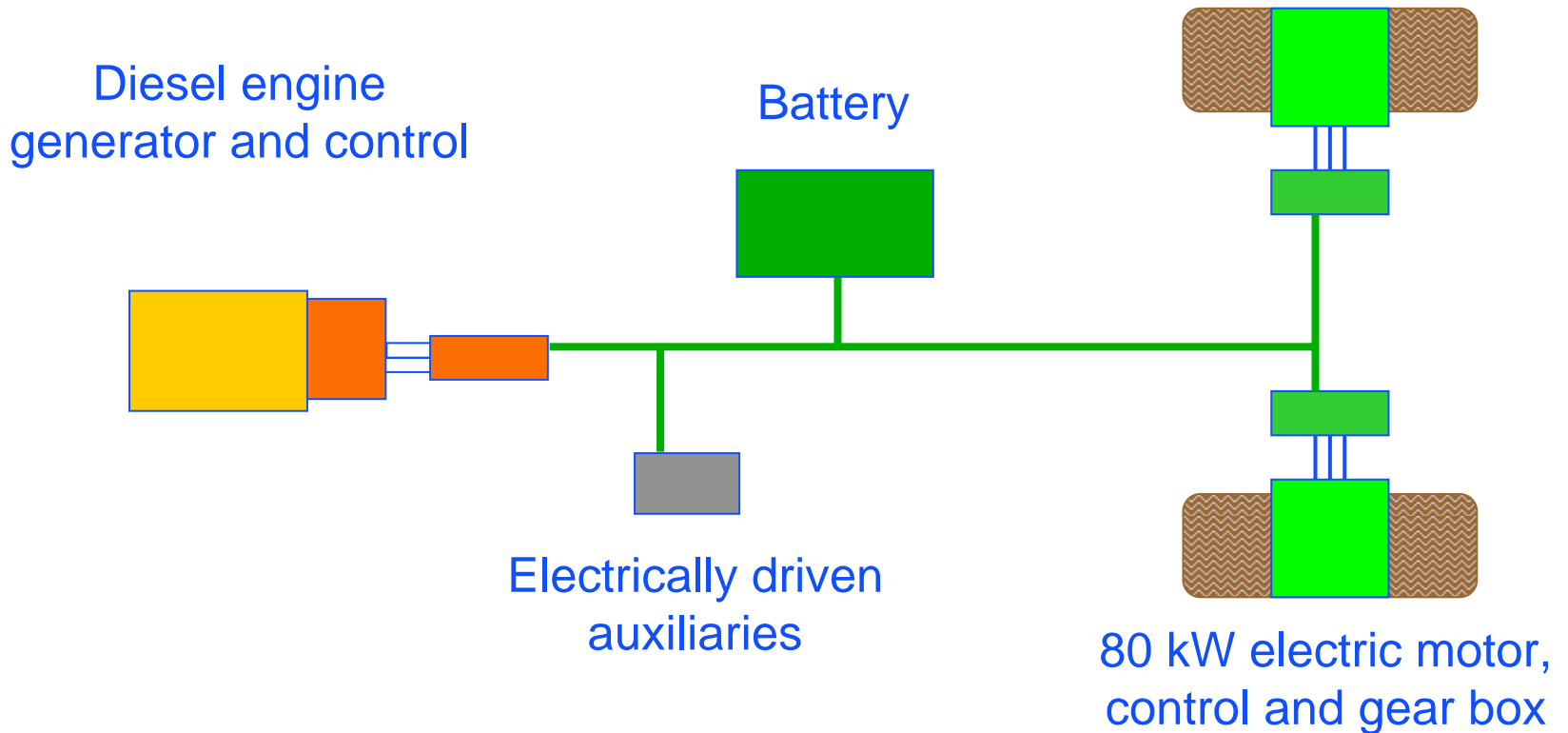

Consumption possible decrease 10 to 30 % / diesel bus
or more (?) depending on bus usage

BAE/Orion VII Hybrid System

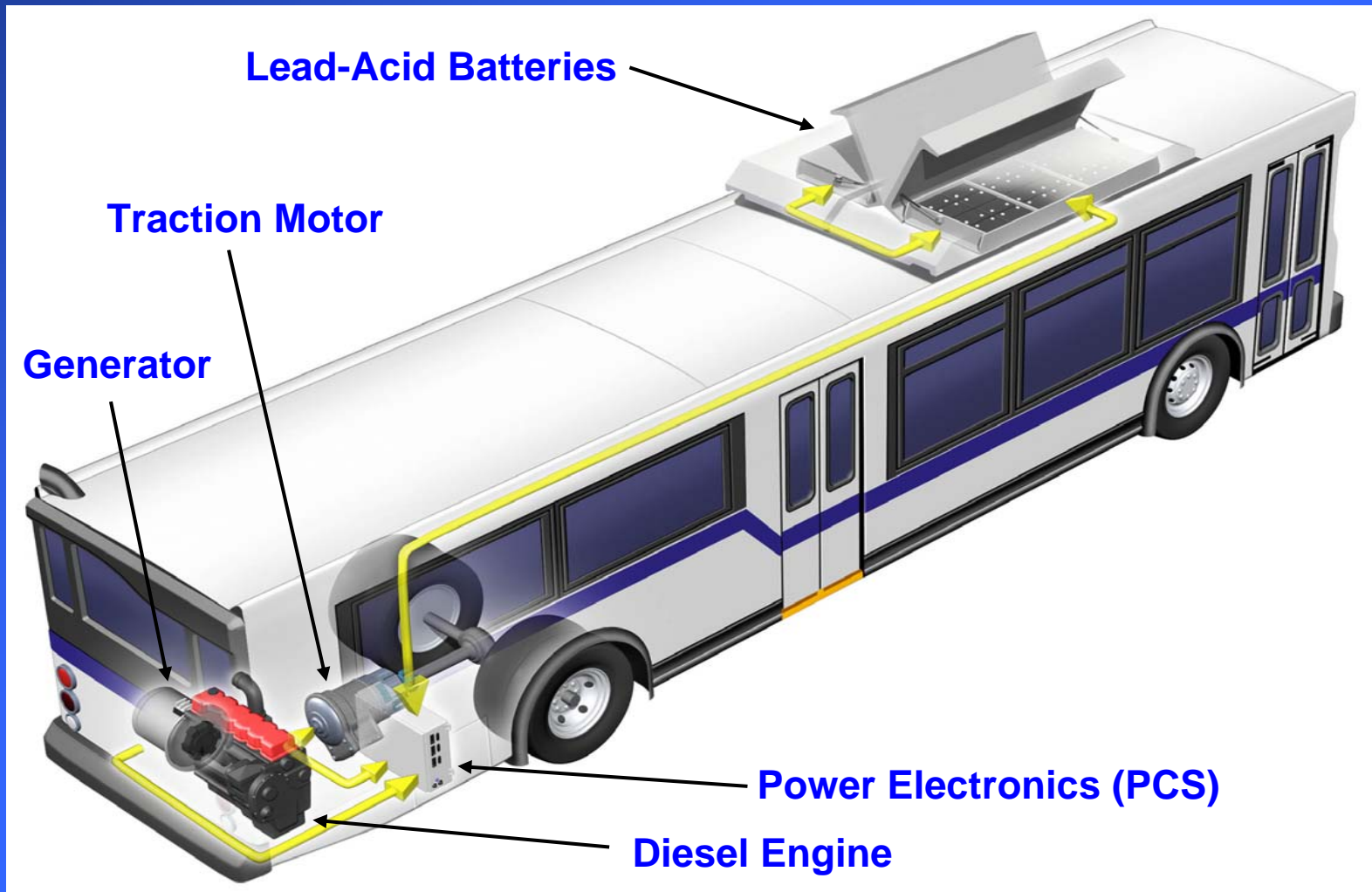



Hybrid and diesel consumption comparison according to vehicle use

From NYCT 2/2000

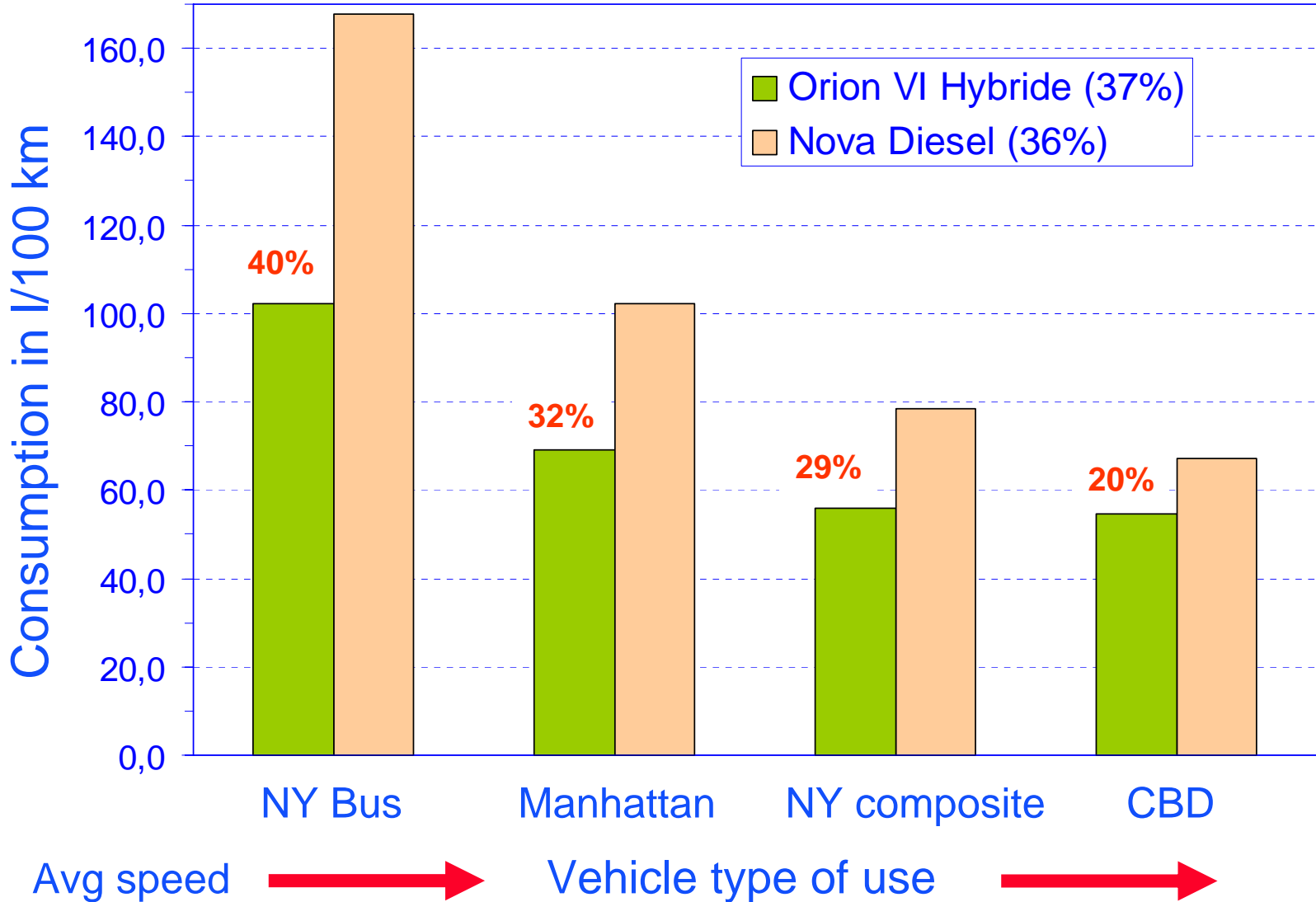



Influence of regeneration on fuel consumption benefit

Same type of vehicle use

Energy recovery on the DC link

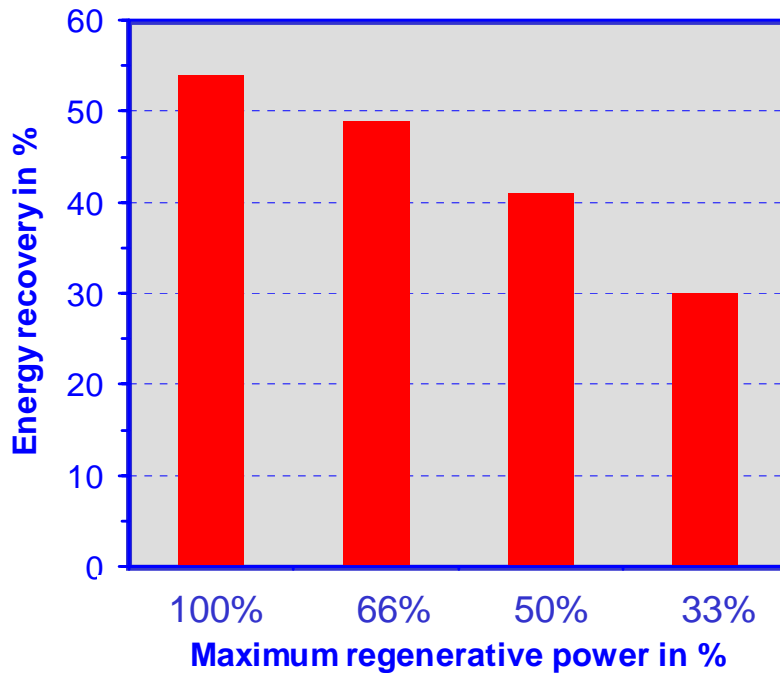

Fuel consumption increase

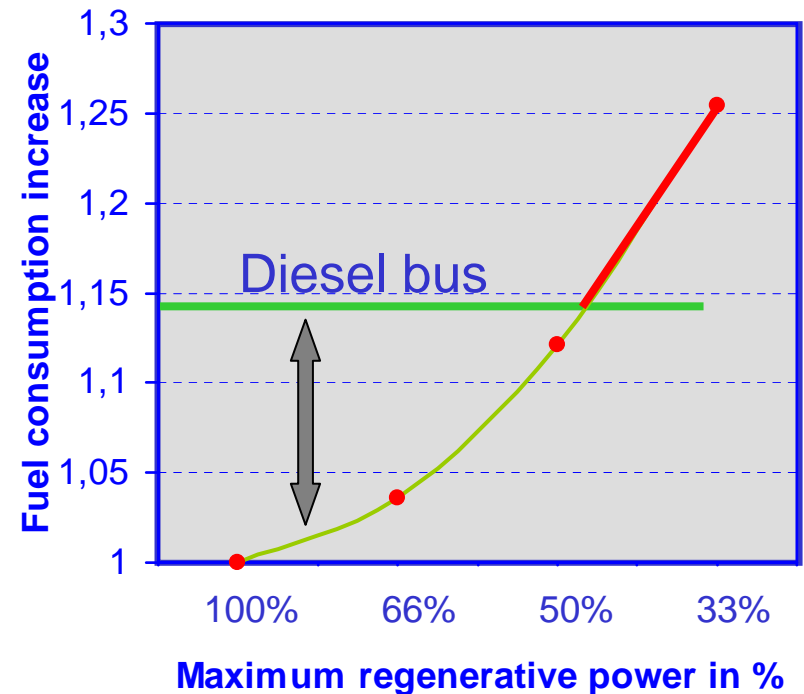

Parallel architecture :

- Engine possibly still connected to the wheels,
- Vehicle propelled by ICE and/or el. machine,
- High drivetrain efficiency,
- Very low architecture modification.

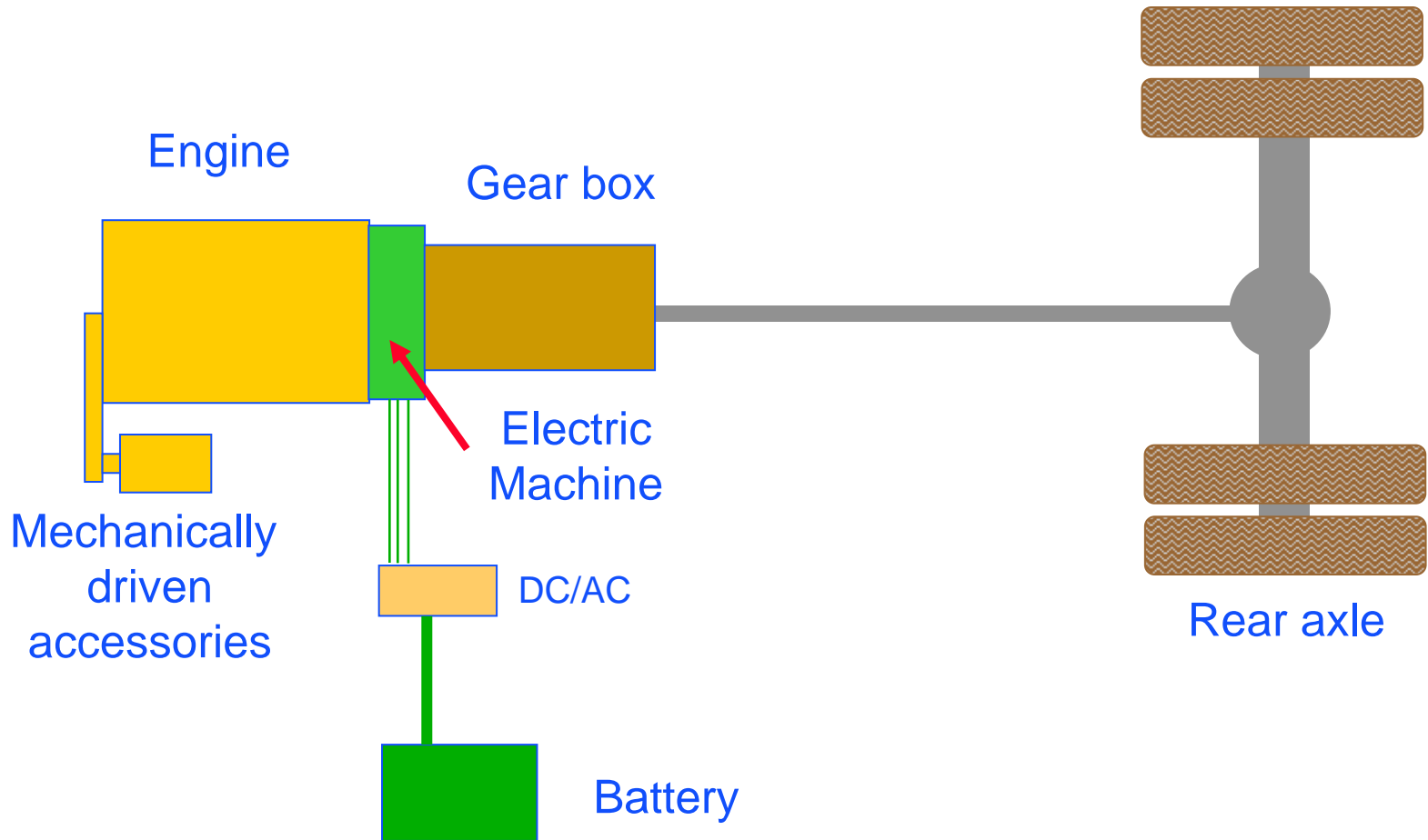

• Basic System Formation

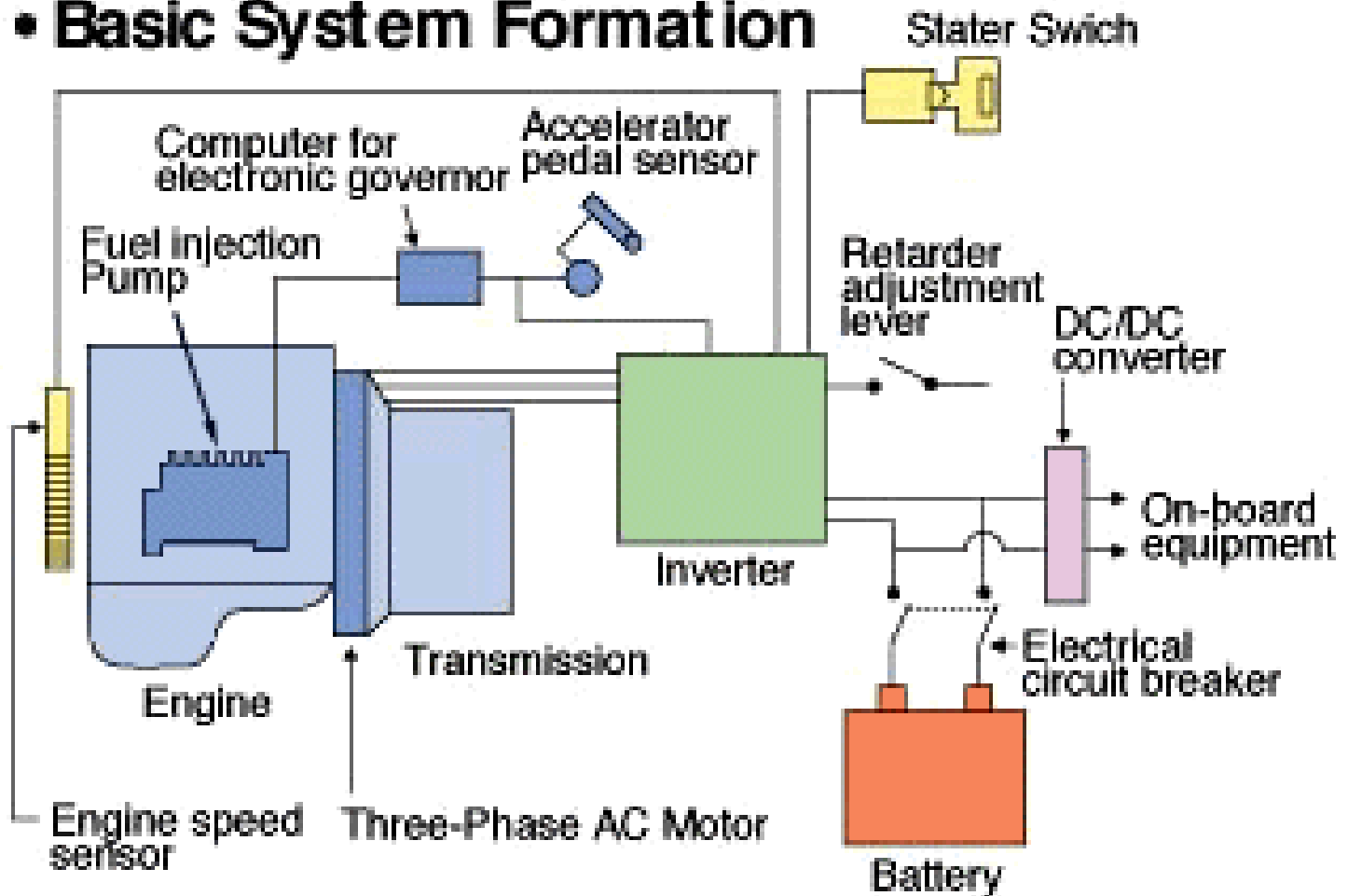



Example of parallel hybrid functionalities



Bus typical cycle

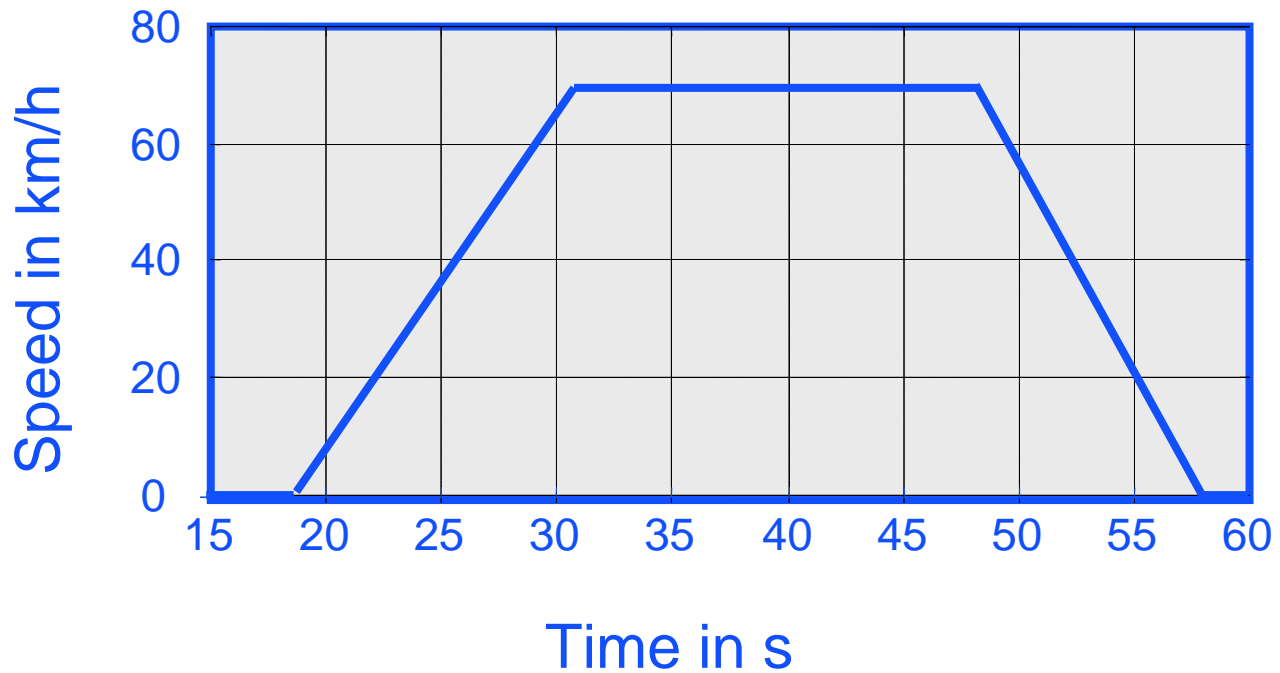



Combined use of ICE and EI machine

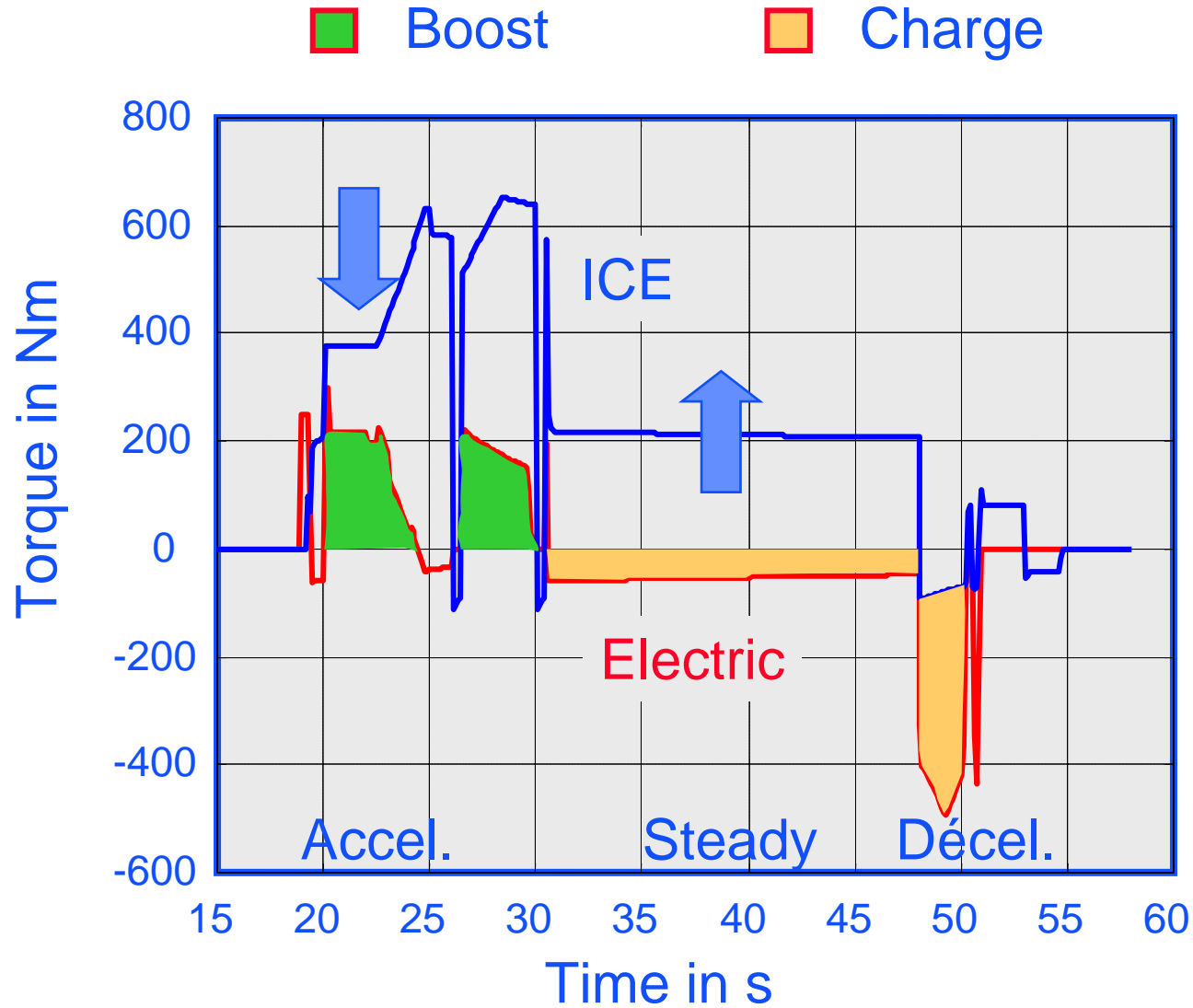

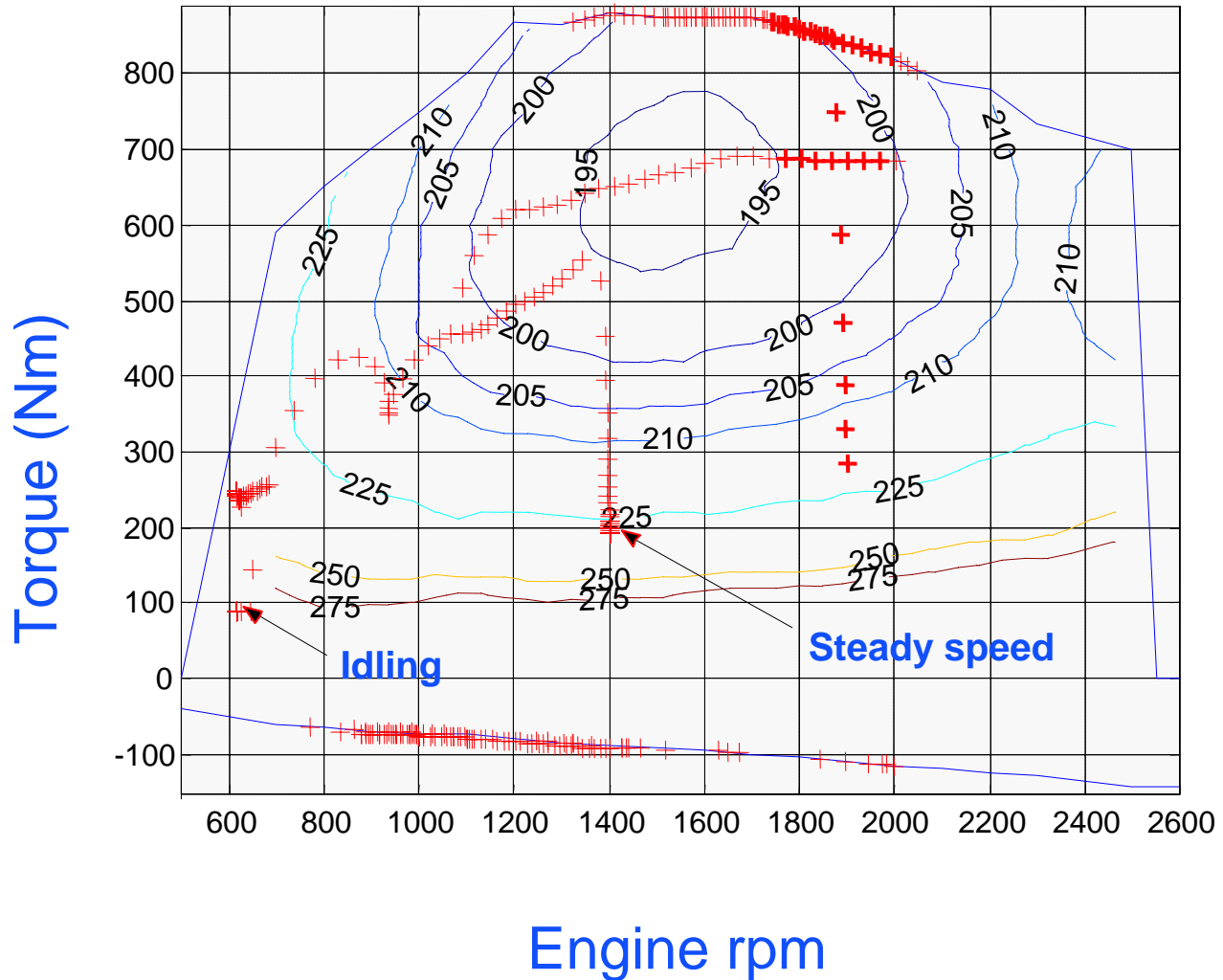



Parallel hybrid drivetrain

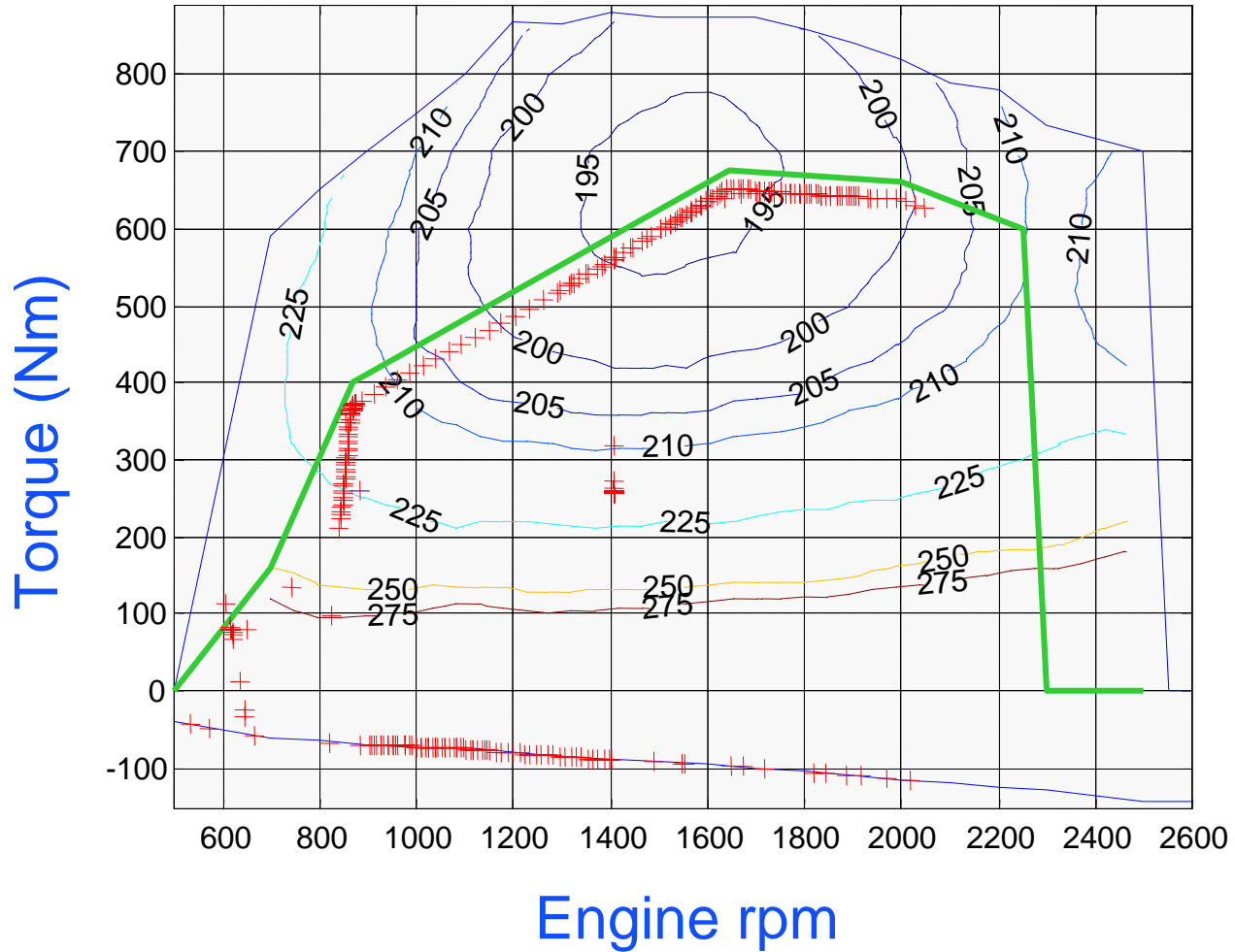

Dual mode (split) architecture :

- Combination of parallel and series architectures
- No drivetrain architecture modification.

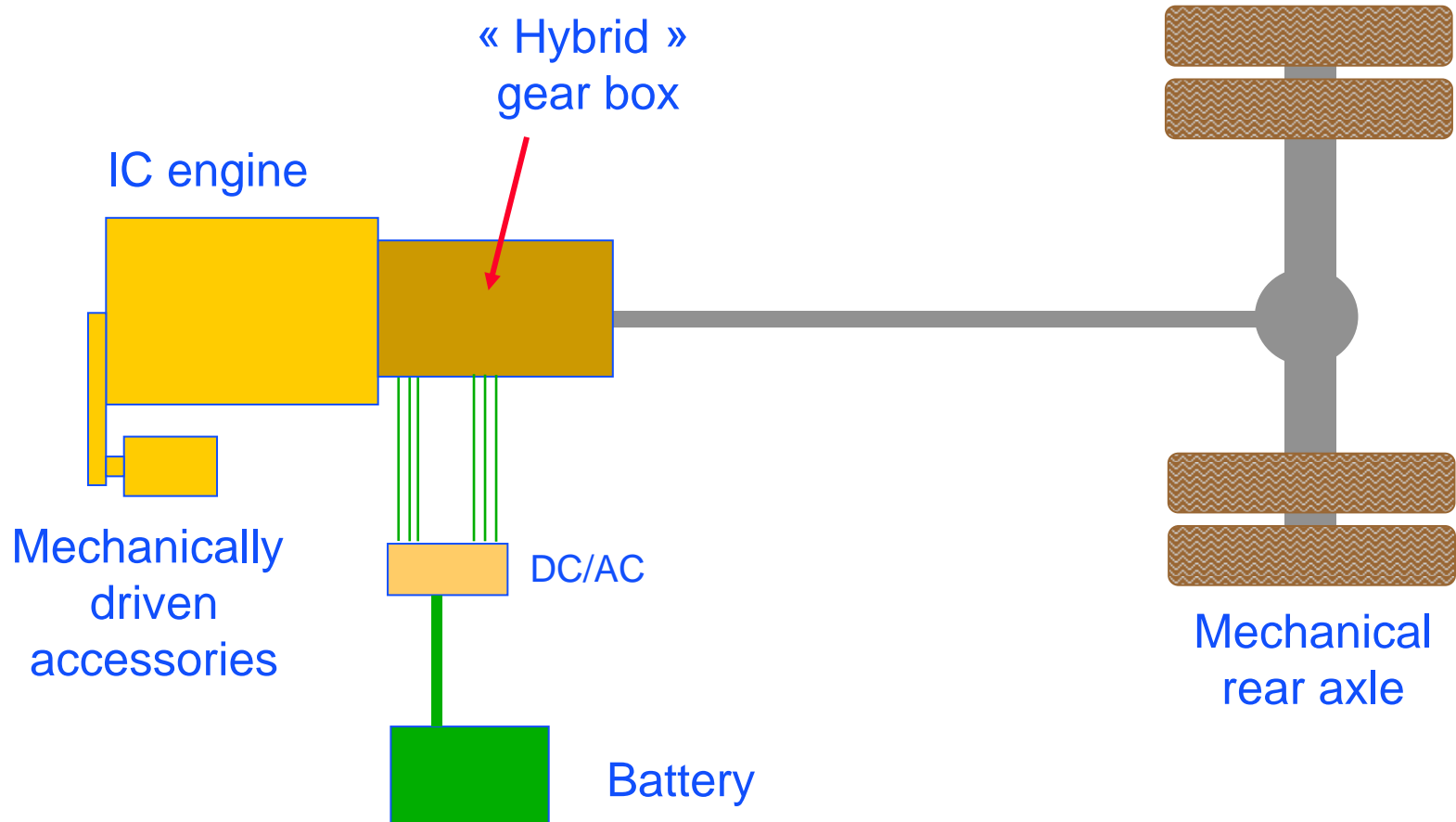



Allison

Concept 3 F (Form, Fit, Function)

Principle

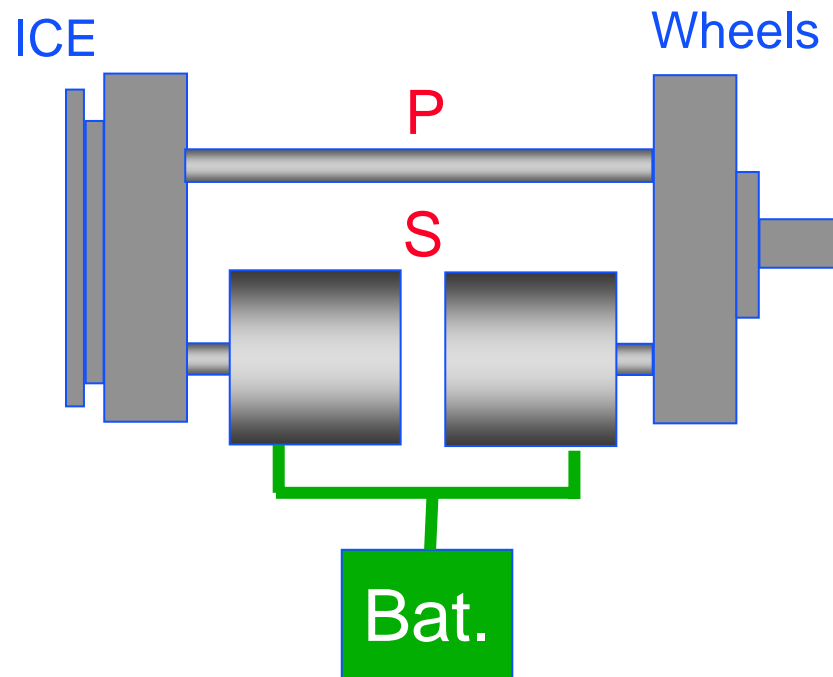

Realization

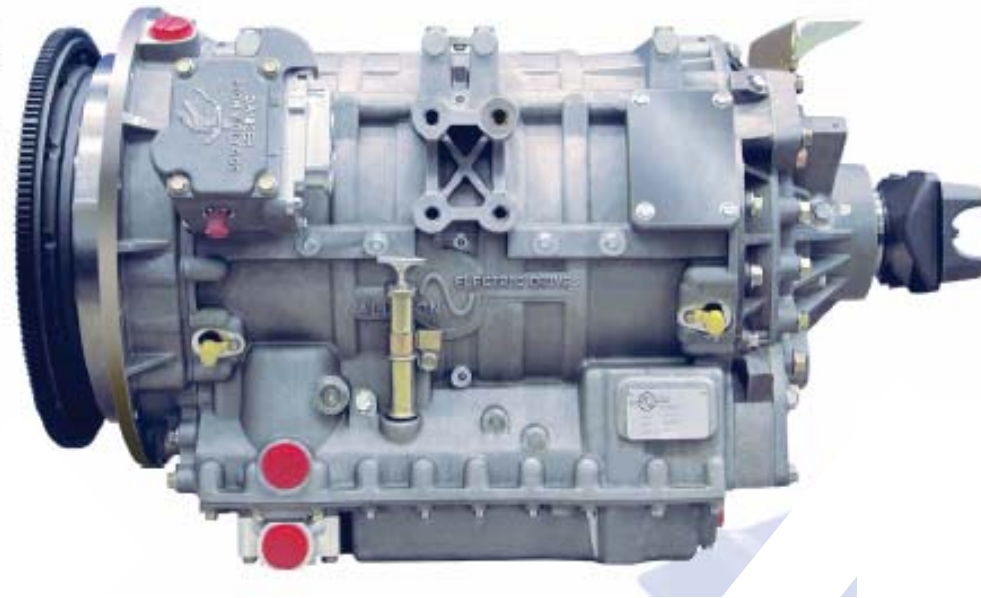

Allison



No drivetrain architecture modification



Allison 2003

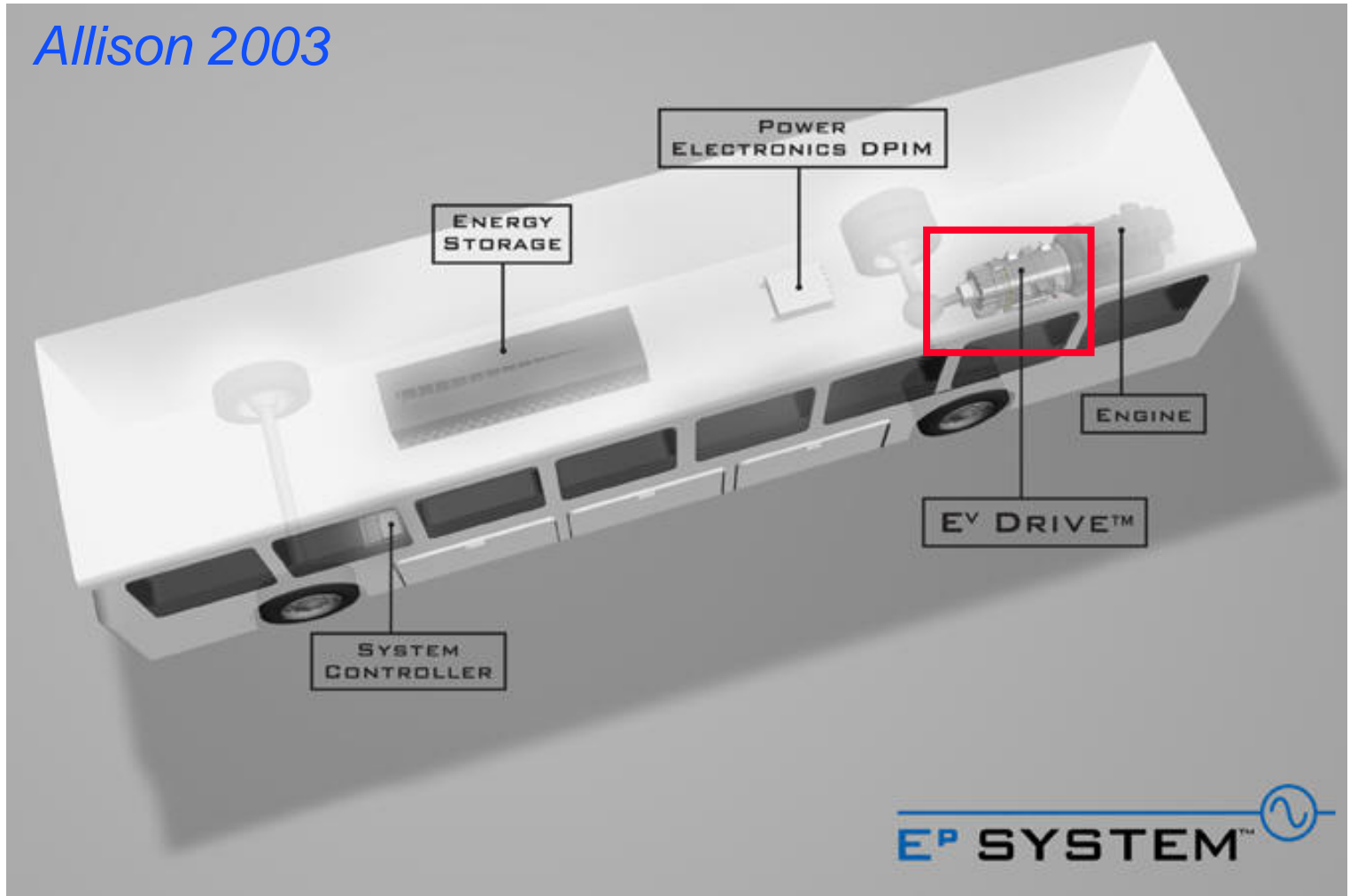



NEW FLYER



Fuel consumption gain in Seattle # 25% (New Flyer)

Nearly 380 GM hybrid-equipped buses operating in 29 cities in the U.S. and Canada (GM)

Purchase and LCC costs ??

Plug in functionality :

- Enables to charge the battery from the grid,
- Possible all electric operation (no local emission),
- Possible energy transfer from petroleum to other primary energy through the electricity vector.

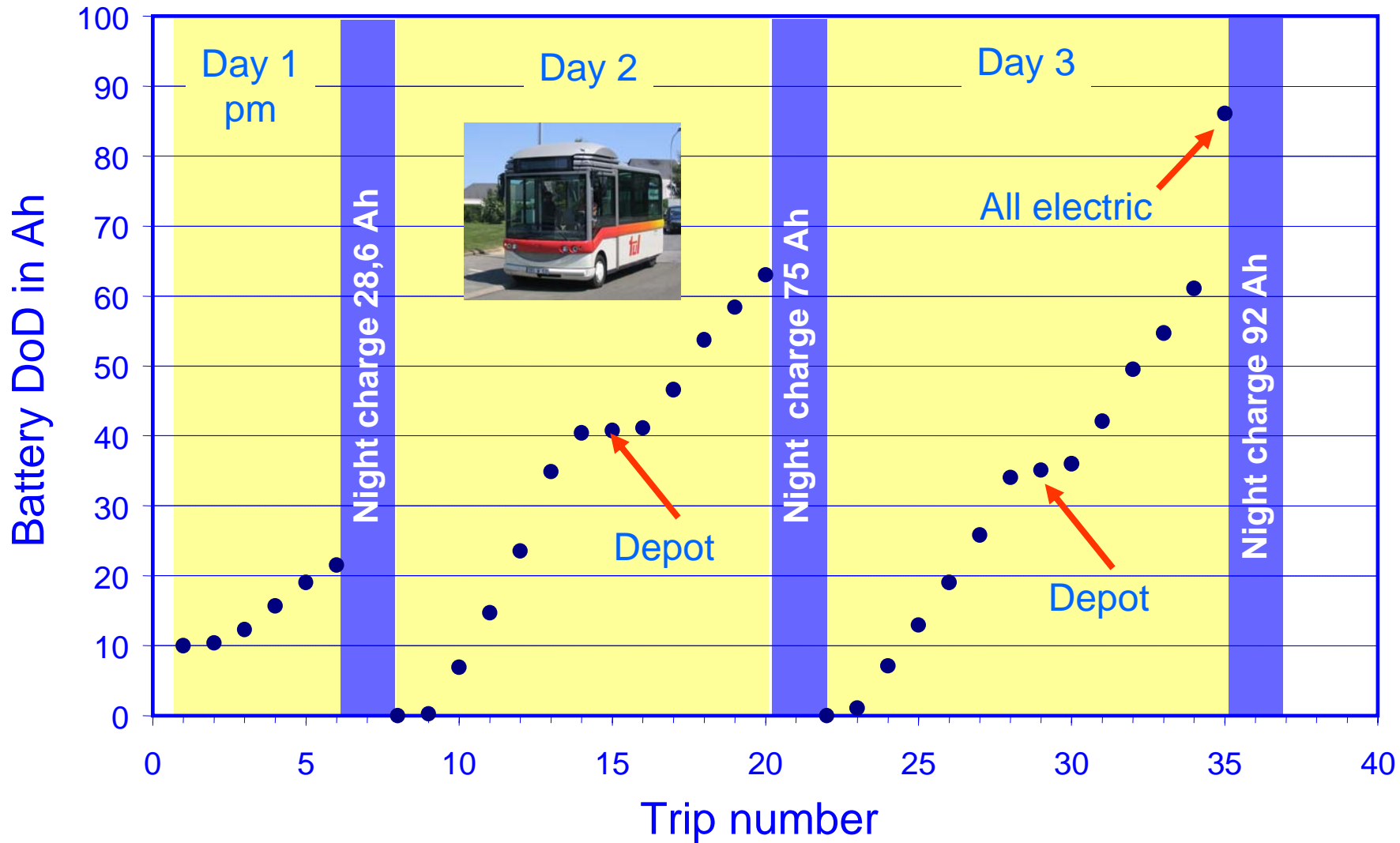

The NY City case

More than 300 hybrid buses in operation
since 1998

Information from :

Gary LaBouff, Director - Research & Development
MTA New York City Transit
(718) 566-3535; gary.labouff@nyct.com

Hybrid/CNG/Diesel Emissions Report

www.navc.org/emissionsreport.html

NREL Reports:

www.afdc.doe.gov/resources.html
reports 6369 and 6383

NYCT Hybrid Bus Programs - Overview

- **Prototype in 1996 (Orion/GE)**
 - **Pilot fleet of 10 Orion VI/BAE hybrid buses began revenue service in 1998 – 700,000 miles**
 - **125 Production Orion VII/BAE Gen. I hybrid buses ordered - pilot bus in 2003, production deliveries in 2004**
 - **200 Production Orion VII/BAE Gen. II hybrid buses ordered - pilot bus in 2004, production deliveries in 2005**
 - **500 Additional Orion VII/BAE Gen. III ordered, (216 NYCT, 284 MTA BUS) - Delivery by 6/07**
-

Bus Fleet Diversification

In 1996, all buses were 40-foot Standard Diesel except for 31 CNG's.

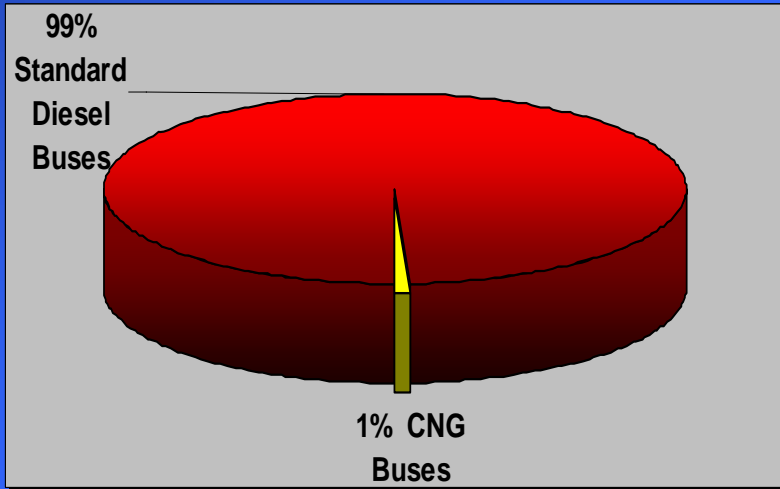

By the end of 2006, only 51% of the fleet will be 40-foot Standard Diesel.

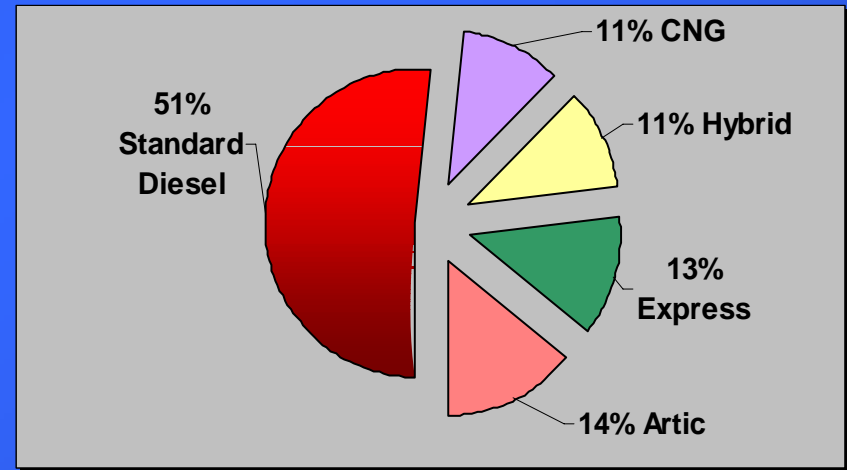

4500 transit buses

NYCT Fleets Composite Fuel Economy

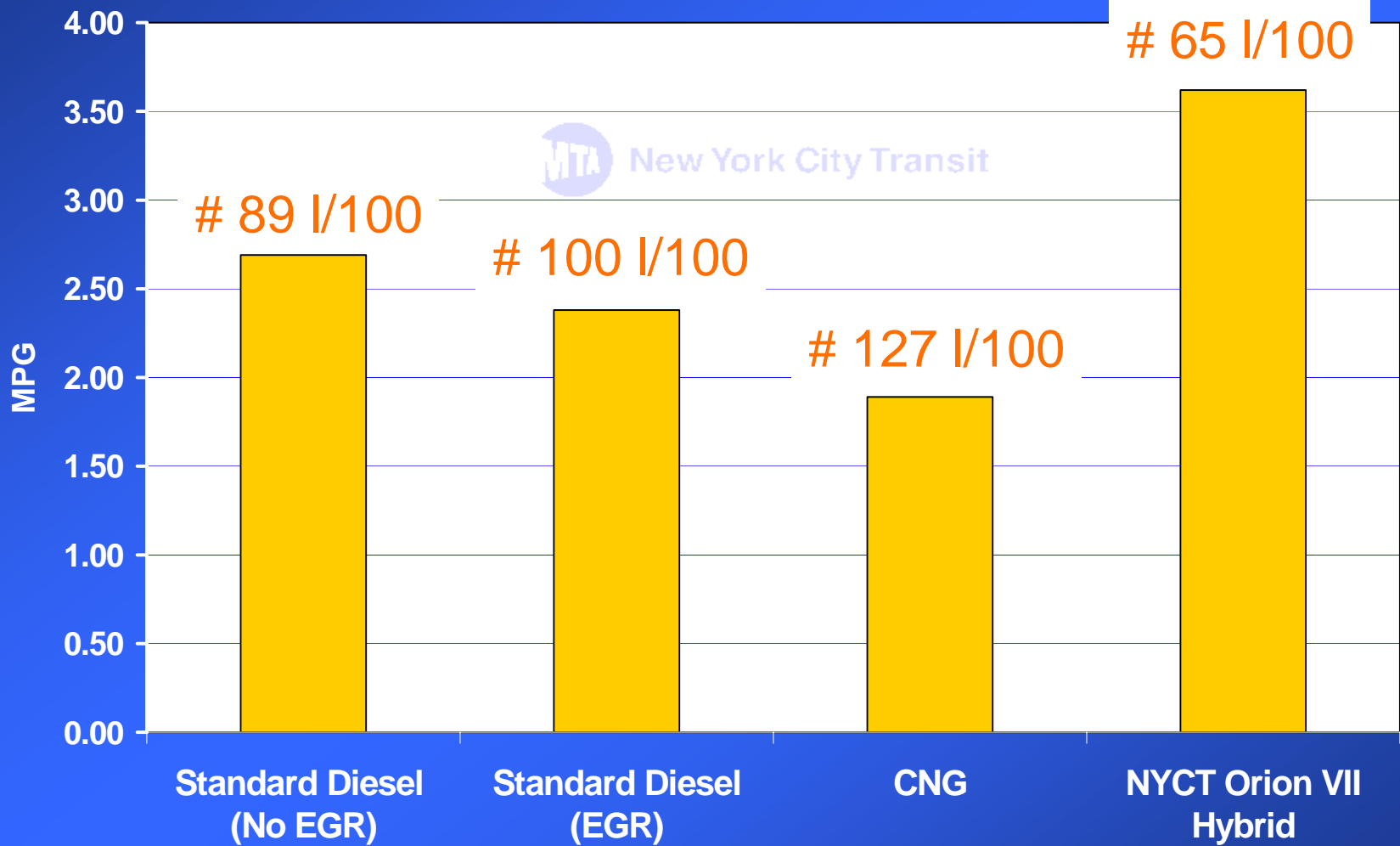

Tailpipe Emissions Comparison

Dynamometer Results - CBD Cycle

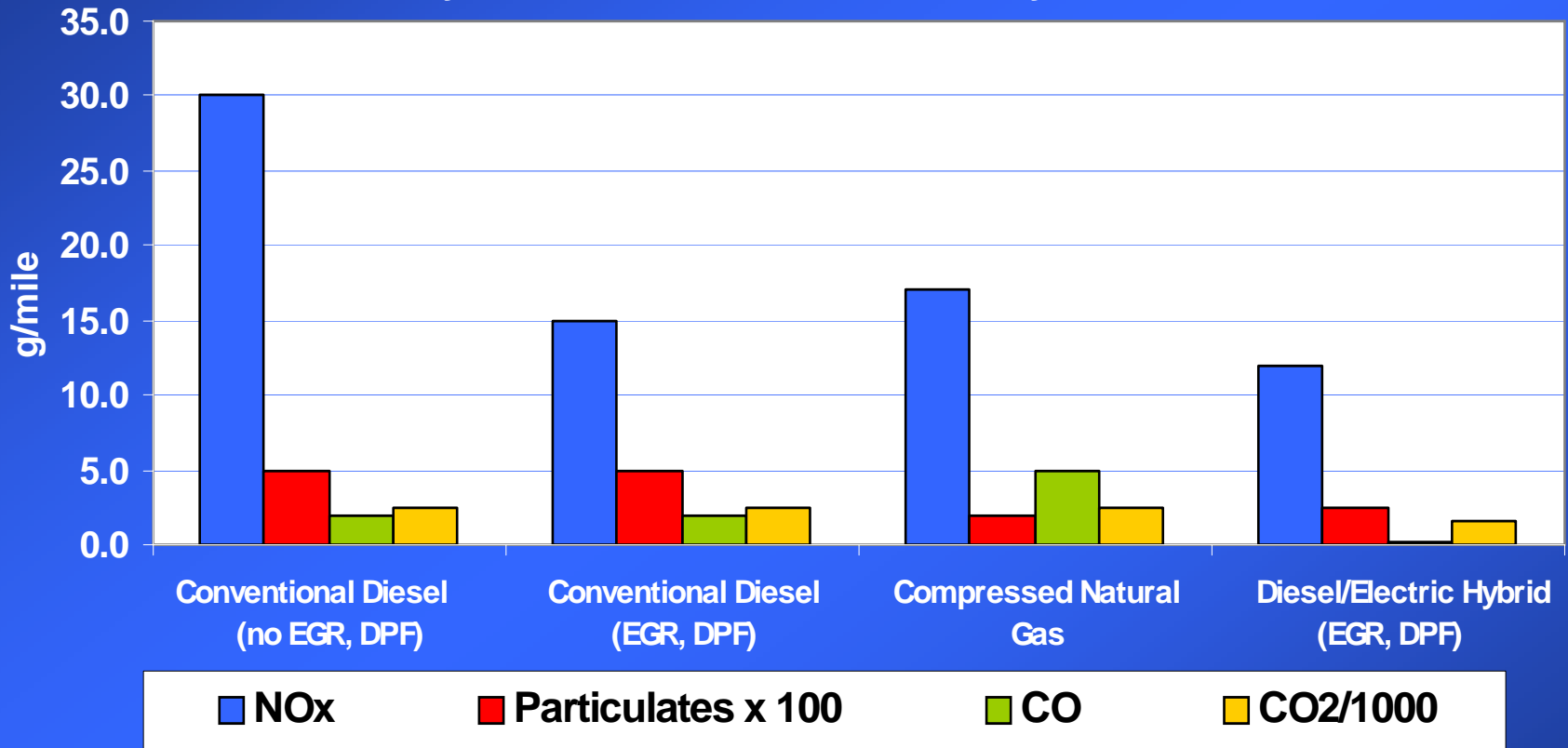

Reference: "Orion VII Transit Bus Equipped with BAE Systems HybriDrive™ Propulsion System (MY 2004): Emissions and Fuel Economy Test Report", Environment Canada Technology Centre, ERMD Final Report #04-18, September 2004.

Potential Hybrid Fuel Cost Savings

Hybrid Bus Compared To Standard Diesel Bus

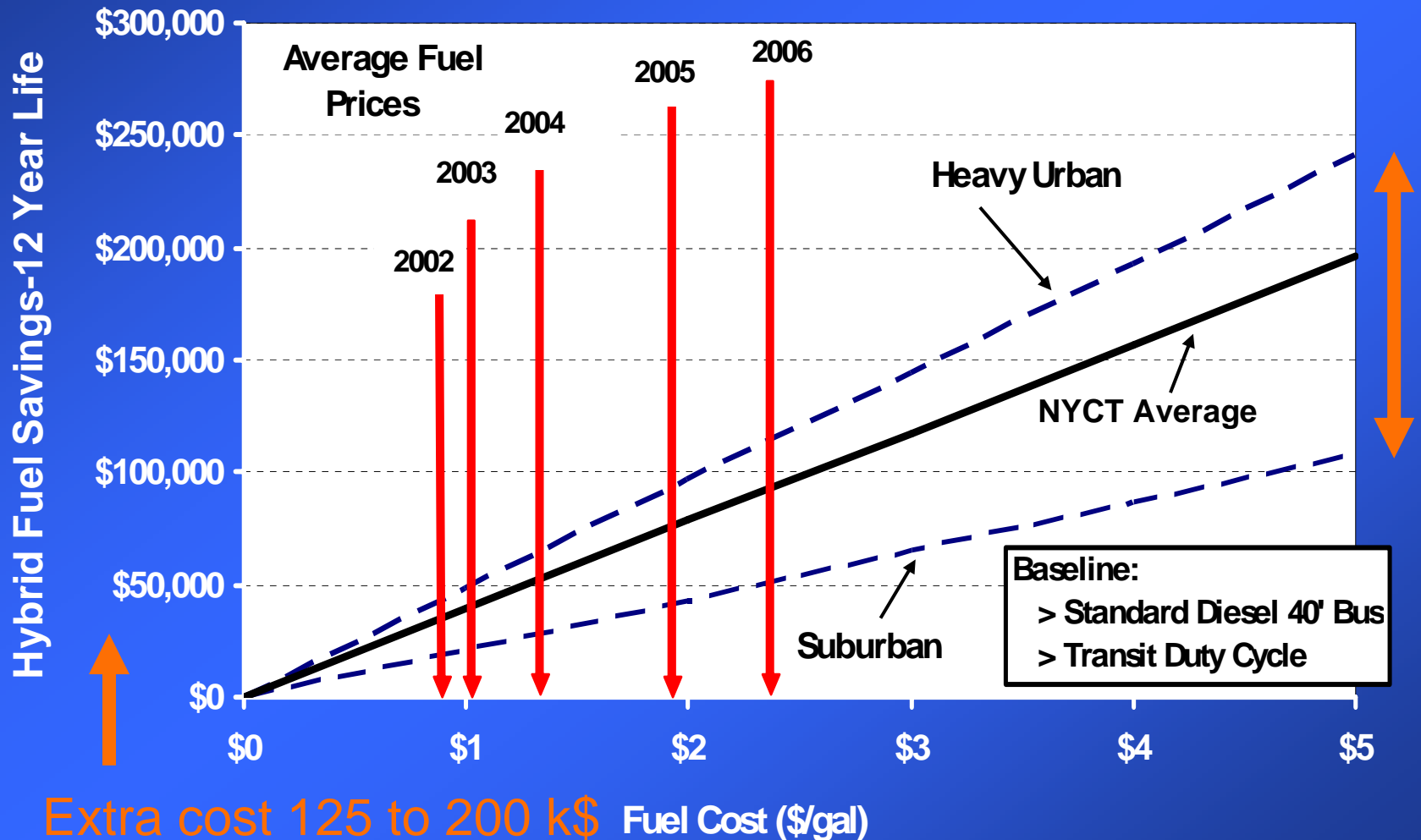

Lessons Learned - Operational

- **Bus operators and passengers like hybrids**
 - Quiet, smooth operation
 - Excellent acceleration/smooth braking
 - “Feels” like a standard bus
 - Little or no operator training required
 - **Able to be used on all NYCT routes**
 - **Bus does not roll back on hills**
-

Lessons Learned - Maintenance

- **More advanced troubleshooting procedures and tools required**
 - More components and subsystems/interfaces
 - More wiring and connectors
 - **Long term, reliable, and cost effective energy storage solution still not clear**
 - Lead acid batteries have limited life and can be reliability drivers due to the number required
 - NiMH life and cost still not demonstrated
 - Ultra capacitors, Lithium Ion batteries still in development
-

Orion VI Lead Acid Battery Life

➤ For the 125 Generation I Bus Fleet:

- 3.73 million battery-miles, **7% (406) replaced** over 2.75 years
- 266 bus-level battery replacement events (213%)

➤ For the 200 Generation II Bus Fleet:

- 3.54 million battery-miles, **1.8% (167) replaced** over 1.7 years
- 145 bus-level battery replacements events (72.5%)

➤ **Most of the battery replacements have not been 'End-of Life' failures**

➤ **Replacement interval for complete battery pack ~~neither defined or observed at this point~~**

NYCT Hybrid Bus - Facilities

- Lead acid batteries require **6 month conditioning cycle**
- Additional equipment for **battery handling and replacement**
- Provision for easy **access to roof** of bus



NYCT Hybrid Bus - Future Plans

- Evaluate other **energy storage** technologies
 - Evaluate other **hybrid system** technologies
 - Continue to develop integrated **diagnostic/prognostic systems**
 - Pursue goal of 7,000+mile MDBF
 - Pursue **all electric accessories**
-

General Bus - Future Challenges

- **Accommodate new emissions control technologies while keeping reliability, maintenance costs, and operating costs at a manageable level**
 - **Keeping maintenance infrastructure current with rapidly changing technologies**
-



Thank you for your attention